

Fuji Dex® 745/765 Remanufacturing Instructions

Oasis Imaging Products Inc. Technical Support (888) 627- 6555



Reference Information:

OEM PN: PKO1

OEM Yield: 12,000 (5% coverage)

Printer Compatibility

Fuji Dex 745, 765

Toshiba TF 531, 551

Recommended Tools:

Flat Head Screwdriver

Approximate Remanufacturing

Time: 40 min.

Instructions:

1. Unclip green brace in back & remove toner cartridge (Fig. 1).
2. Vacuum out excess toner from developer well (Fig. 2).
3. Remove 3 screws (Fig. 2), remove metal plate & Corona contact.
4. Remove Corona assembly (Fig. 3). Inspect & clean.
5. Remove 3 screws from right side (Fig. 4) & remove plate.
6. Remove 3 screws from left side (Fig. 5) & remove plate.
7. Pull developer section straight back (Fig. 6). **Note:** Be careful, all gears are loose.
8. Remove "C" clip from right side (Fig. 6) & pull rod straight out.
9. Remove OPC, clean, inspect, replace if necessary.
10. Remove 3 screws to wiper blade (Fig. 3). Peel back felt off of wiper blade (Fig. 7).
11. Remove wiper blade. Clean & inspect.
12. Remove screw on top of waste hopper. (Fig. 3)
13. Remove top of waste hopper & vacuum. (Fig. 8)
14. Replace wiper blade.
15. Replace OPC drum & rod.
16. Clean main roller & feed roller.

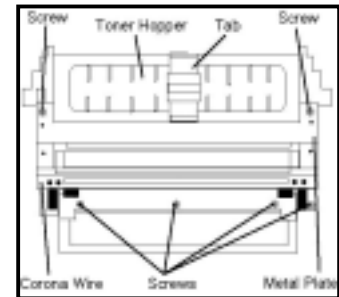

Figure 1

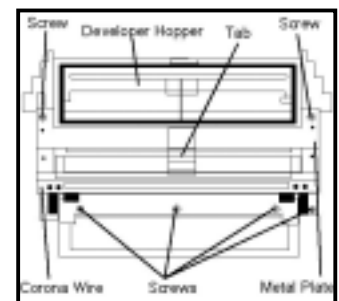

Figure 2

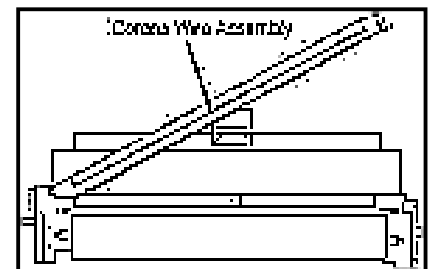

Figure 3

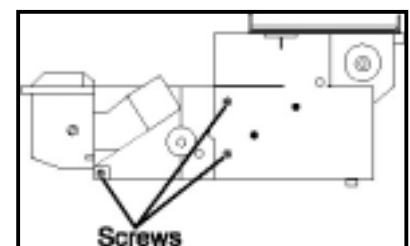

Figure 4

17. Join OPC section to developer section.
18. Replace left & right covers and screw down.
19. Replace corona assembly & corona contact and screw down.
20. Replace metal plate & screw down.

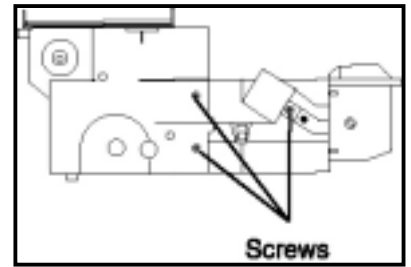

Figure 5

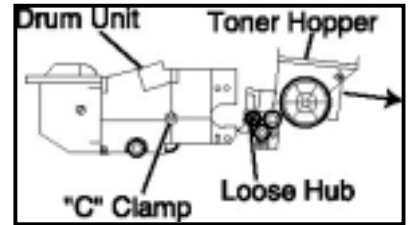

Figure 6

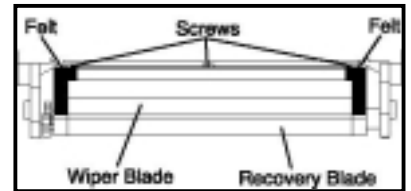

Figure 7



Figure 8